

Design Guidelines
City Of Osage Beach
SECTION 3 - SEWERAGE DESIGN

(Revised 27 JUNE 2018 - NLE)

GENERAL

The City of Osage Beach operates a sewage collection and treatment system in accordance with the Missouri Department of Natural Resources (MDNR) regulations. The system is comprised of pressure and gravity sewer lines, grinder stations, lift stations, and a jointly owned regional sewage treatment facility. The plant is managed by the Lake Ozark / Osage Beach Joint Sewer Board. The collection system within Osage Beach, and from the city to the plant, is owned and operated by the City of Osage Beach. At the current time, there are a few isolated areas within the city that are not served by the collection system. It is the policy of the city that all occupied facilities within the city will have city sewer service.

At the present time, there are over 1125 grinder stations and 56 sewage lift stations. These stations have been standardized to use ABS/Sulzer pumps and appurtenances. This practice shall continue until determined by the city to be infeasible or otherwise unsatisfactory.

All modifications to the sewage treatment plant or the sewage collection system shall conform to the MDNR regulations and polices as supplemented herein.

REFERENCED CITY ORDINANCES

Chapter 400.110 Subdivision Regulations
Chapter 410.130 Contents (Location and design of water mains and appurtenances)
Chapter 410.190 Design Standards
Chapter 410.260 Location of Utilities in Right-of-Ways
Chapter 410.330 Sanitary Sewers
Chapter 710 Sewers and Sewerage Systems

SEWERAGE DESIGN

1. Waste Water Treatment Facility; Modifications to the existing treatment facility must be made under the direction of the Lake Ozark / Osage Beach Joint Sewer Board. Such modifications must be designed in accordance with, and approved by, the MDNR. If the city needs to have changes made in the plant, they must forward the request to the Joint Sewer Board.
2. Sewage Collection System; Modifications of, and additions to, the existing sewage collection system shall be made in accordance with MDNR regulations as supplemented herein.

Design Guidelines
City Of Osage Beach
SECTION 3 - SEWERAGE DESIGN

3. Hydraulic Design shall be based upon the following criterion:

AVERAGE DAILY FLOWS		
Type of Establishment	Pounds BOD per person	Gallons/Day per person
<u>Residential</u>		
Single family	0.17	100
Apartments	0.17	100
Condos	0.17	100
<u>Commercial Food & Drink</u>		
Tavern	0.01	2
Fast food	0.02	5
Restaurant	0.04	5
(with garbage grinder)	0.07	6
Car Wash (10.3 gpd/sf) (31.5 gpm Peak Hour / Bay)		See data To left
<u>Institutions</u>		
Day school		
W/ gym & showers	0.03	20
W/ cafeteria - ADD	0.02	4
W/ garbage grinding - ADD	0.02	1
Hospital - per bed	0.22	200
Nursing homes	0.17	125
Park restroom	0.02	5
Park restroom w/showers	0.06	25
Swimming pools	0.06	25
Country club per resident	0.17	100
Country club per member	0.06	25
Service Stations	0.01	5
Laundromats per machine	1.25	580
Hotels	0.15	50
Motel w/o restaurant	0.1	40
Luxury Resort	0.17	75
Camp trailer	0.08	30
Churches per seat	0.01	5
Stores, shopping centers, malls per 1000 sf of floor area	0.34	200
Stadiums, auditoriums, theaters or drive-ins per seat	0.01	5
*Includes infiltration		

Design Guidelines
City Of Osage Beach
SECTION 3 - SEWERAGE DESIGN

EQUIVALENT POPULATION

Facility	Persons/Unit
Single family residence	3.7
Apartment or condo	
one bedroom	2
two bedrooms	3
three bedrooms	3.7
Mobile homes	3
Camper trailer	3
Motels per room	3

PEAK HOURLY FLOW = 4 X AVERAGE DAILY FLOW

4. Gravity Sewers design shall conform to the applicable Missouri Department of Natural Resources regulations and as specified herein. The peak hourly flow shall be determined and the gravity line sized accordingly with the following additions:
 - a. Gravity sewer laterals from a residence to grinder station or main:
 - 1) Shall be not less than 4-inch pipe.
 - 2) Shall have a cleanout located within 5 feet of the residence and at all vertical and horizontal bends; a sanitary tee within 5 feet of the grinder station or main; and a backflow valve adjacent the grinder station.
 - 3) Shall not exceed 150 feet in length. Residence service lines over 150 feet in length shall be treated as sewer mains.
 - 4) Shall be SCH 40 with SCH 40 fittings or ASTM D3034 DR 26 PVC with sanitary sewer DR 26 PVC or ductile iron fittings.
 - 5) All bends shall be long radius bends. Short radius 90° bends are specifically prohibited.
 - b. Gravity Sewer mains:
 - 1) Sewer mains shall be designed for the peak hourly flow and shall be not less than 8-inch pipe.
 - 2) Gravity sewer pipe shall be:
 - a) Ductile iron, ASTM A746, Class 350 with cement lining. Ductile iron Push-on type joints and fittings shall be used, or
 - b) ASTM 2241, DR 21, Class 150 with approved fittings.
 - c) PVC, ASTM D3034, SDR 26, with SDR 26 PVC sanitary fittings.
 - d) ASTM D3034, SDR 35, with SDR 35 fittings where maximum depth of cover is eight (8) feet or less.
 - e) SCH 40 PVC with SCH 40 fittings
 - 3) Manholes shall be constructed at the end of main and at changes in horizontal or vertical alignment, or not more than every 350 feet.
 - 4) When a residence service line will exceed 150 feet, a manhole shall be constructed with a 4-inch service line to the residence and a minimum eight-inch main to remainder of the system.

Design Guidelines
City Of Osage Beach
SECTION 3 - SEWERAGE DESIGN

- 5) All bends shall be long radius bends. Short radius 90° bends are specifically prohibited.
- c. Connections to sewer mains shall be made using a sanitary wye tapping fitting.
- d. Connections to grinder pump basins:
 - 1) Shall be made using a cast iron inlet hub of appropriate diameter and shall be bolted to the grinder basin and sealed with an approved silicone seal. A PVC backflow valve (check valve) shall be installed within 2 feet of the basin.
 - 2) Inlet pipes shall be installed a minimum of four feet above the bottom of the grinder basin and not less than 18 inches below the top of the basin.
- e. Bedding:
 - 1) Shall be installed around the pipe from 3 inches below to 12 inches above the pipe. Bedding shall be nominal ½ inch minus crushed rock conforming to MoDOT Section 1004, Grade D, Chat, or pea-gravel, or Osage River Sand. Any material used shall have a PI of six or less.
- f. Detectable Marking Tape and Toning Wire:
 - 1) Metallic detectable marking tape, Type III, shall be placed in the trench above all sewers, gravity and pressure, one foot above the pipe.
 - 2) No. 12 solid copper toning wire shall be located three inches above the sewer line and shall be continuous from terminus to terminus and shall include all city owned sewers.
- g. Minimum grades for gravity sewers:
 - 1) 4-inch sewer shall be not less than 1.00%
 - 2) 6 inch sewer shall be not less than 0.67%
 - 3) 8 inch sewer shall be not less than 0.50%
 - 4) 10 inch sewer shall be not less than 0.33%
 - 5) Larger shall be as approved by the City Engineer
- h. Minimum depth of cover for gravity sewers:
 - 1) Shall be not less than 18 inches above the top of pipe
- i. Maximum depth of cover shall be eight (8) feet unless specifically authorized in writing by the City Engineer.
- j. Manholes:
 - 1) Shall be as detailed in the Osage Beach Design Guideline
 - 2) Or as approved by the City Engineer
- k. Valve Boxes:
 - 1) Shall be Buffalo type with cast iron lid marked “sewer”.
- l. Leak testing for gravity sewers:
 - 1) Gravity sewer lines may be tested by air or water method.
 - a) Water Tests: Gravity sewer lines shall be plugged at the bottom end and filled with water to the top of the next upstream manhole; or if no manhole, to the top of the farthest upstream cleanout; and left for twenty-four hours. The line shall then be refilled with a measured amount of water. The allowable leakage shall be one gallon per hundred feet of line tested.
 - b) Air Tests: Test lines between manholes with low-pressure air. Safety requires a regulator or relief valve on pressurizing

Design Guidelines
City Of Osage Beach
SECTION 3 - SEWERAGE DESIGN

equipment, set at 8 psig. No one will be allowed in manholes while there is air pressure against test plugs.

- 1) Plug all pipe outlets to resist test pressure. Give special attention to laterals.
- 2) Plug all other pipes in both upstream and downstream manholes and fill manholes with clear water to just above the line plugged for testing. Any bubbles appearing during the test indicate leakage past a plug or in part of the test equipment.
- 3) Compute the test pressure by multiplying 0.43 times the elevation difference (in feet) of the upstream manhole rim and the invert of the line under test at the downstream manhole. The result is in psig and may be rounded to the nearest half psig. The test pressure shall be not less than 3.5 psig, nor more than 6.0 psig. Total line length included in any test section shall not exceed 400 feet.
- 4) Supply air into the line until test pressure is attained. Allow at least 5 minutes for air temperature in the test section to stabilize.
- 5) Reestablish the test pressure, and start a stop watch. Determine the time required for pressure to drop 0.5 psig.
- 6) If the pressure does not drop during the stabilization period, and no additional air has been added, the section undergoing test will have passed without further testing.
- 7) The pipe section will also have passed if the time observed for the pressure to drop 0.5 psig is greater than that determined by using the following table:

Pipe Size, Inches	Time
4	4 minutes 2 seconds
6	6 minutes 0 seconds
8	7 minutes 37 seconds
10	9 minutes 8 seconds
12	10 minutes 58 seconds
14	12 minutes 30 seconds
16	14 minutes 32 seconds

When a combination of more than one pipe size is under test, the calculated time for the larger pipe shall apply.

Design Guidelines
City Of Osage Beach
SECTION 3 - SEWERAGE DESIGN

- 2) Manholes may be tested by vacuum or water method.
 - a) Water Method: Manholes shall be tested by plugging inlet and outlet pipes and filling with water to the top of the manhole cover ring and letting set for twenty-four hours. The maximum leakage shall be a drop in water level of three inches.
5. Pressure Sewers design shall conform to MDNR requirements and as supplemented herein. The design of additions to the city sewer system shall minimize the need for pressure sewer to the maximum extent practicable in order to reduce the number of lift or grinder stations to the minimum required. Pressure sewers shall conform to the following criterion:
 - a. Pressure sewers shall be designed for flow rates between 2.0 fps and a maximum of 5.0 fps. The minimum diameter of pipe used shall be 1-1/4 inches.
 - b. Pressure pipe:
 - 1) Less than four inches in diameter shall be schedule 80 PVC or ASTM 2241, DR 21, Class 150, or HDPE AWWA C906, DR 9 copper tube size.
 - 2) Four inches and larger shall be: AWWA C151 Class 350 ductile iron, or AWWA C900 DR 18 Class 150 PVC.
 - c. Joints:
 - 1) For SCH 80 pipe shall be solvent welded.
 - 2) For other pipe shall be neoprene lined push-on type joints or as approved by the City Engineer.
 - d. Fittings:
 - 1) For Schedule 80 pipe shall be Schedule 80 fittings.
 - 2) For other pipe may be appropriately rated and compatible PVC or ductile iron on PVC and shall be ductile iron on ductile iron sewers. All fittings shall be neoprene gasket push-on type or as approved by the City Engineer.
 - 3) Long radius bends or multiple fittings shall be used. The use of short radius 90° bends is prohibited.
 - e. The minimum cover for pressure sewer is 36 inches.
 - f. The maximum depth of cover for pressure sewers is eight (8) feet unless specifically authorized in writing by the City Engineer.
 - g. Bedding shall be installed around the pipe from 3 inches below to 12 inches above the pipe. Bedding shall be nominal ½ inch minus crushed rock conforming to MoDOT Section 1004, Grade D, Chat. Any material used shall have a PI of six or less.
 - h. Detectable marking tape and Toning Wire:
 - 1) A metallic detectable marking tape, Type III, marked “Sewer Below” shall be placed in the trench one foot above all pressure sewers pipe.
 - 2) A No. 12 solid copper toning wire shall be installed three inches above the pressure sewer and shall extend from terminus to terminus.
 - i. The check valve shall be brass body, single flap type.
 - j. The inlet connection hub shall be cast iron inlet hub bolted to the basin. The back of the hub shall be sealed to the basin using approved silicone sealant. Appropriate inlet hubs are stocked by the ABS supplier.

Design Guidelines
City Of Osage Beach
SECTION 3 - SEWERAGE DESIGN

- k. An isolation valve shall be installed at the connection to the sewer main. The valve shall be brass body, globe valve of the same nominal size as the pressure sewer shall be installed at the connection to the sewer force main. The valve should be located so as to be outside roadway or other similar traffic areas. The globe valve shall have integral checks for open and closed positions. The valve shall be placed upon a concrete, or approved, masonry pedestal to prevent settlement; shall be covered with a buffalo type valve box and cover extended to one inch above the finished surface. If the finished surface is concrete or asphalt pavement in which case the valve box cover shall be flush with the paved surface. Valve box covers on pressure sewers shall be marked "SEWER". The markings shall be cast into the cover.
- l. The tapping saddle shall be Brass similar and equal to Ford. The tapping saddle shall be sealed to the pipe by means of a rubber "O" ring seal to provide a connection suitable for a working pressure of 200 psi. Tapping saddles shall have flanged or threaded outlets conforming to ANSI B16.1. If at all possible, all tapping saddles shall be in the horizontal position. Under no circumstances shall anyone make a wet tap without approval and authorization by the City Public Works Director.
- m. Leakage test: Testing procedure is as follows:
 - a. Upon completion of the water main it shall be cleaned and all dirt, trash, debris, and deleterious materials removed from the line.
 - b. Filled to capacity and all extraneous air removed.
 - c. Pressurize to 75 psi above normal working pressure at the test location and hold for a period of not less than two hours.
 - d. At the end of the testing period the line shall be refilled with water and the amount of water to refill the line shall be measured and recorded.
 - e. The amount of water to refill the line must be less than the maximum allowable leakage. The maximum allowable leakage shall be computed thusly:

$$Q_{Loss} = SDP^{1/2} / 133000$$

Where:

Q_{Loss} = Maximum allowable leakage
S = Length of the section tested in feet
D = Diameter of the pipe in inches
P = Test Pressure, PSI

DESIGN OF GRINDER PUMPS AND SEWAGE LIFT STATIONS

The design of grinder pump installation shall be certified by a Registered Professional Engineer and shall conform to MDNR and the City Of Osage Beach requirements. In order to reduce maintenance and operational cost, the city has selected ABS / Sulzer pumps and equipment as their standard. Accordingly, all grinder pumps and lift stations shall be designed using ABS /

Design Guidelines
City Of Osage Beach
SECTION 3 - SEWERAGE DESIGN

Sulzer equipment unless specifically authorized by the City Engineer. The size, type, and capacity of the grinder pump, or lift station, shall be based upon the hydraulic loading and gradient necessary to pump sewage from the source to an appropriate location.

1. Hydraulic Design Considerations

- a. Using the previously presented charts determine the following:
 - 1) Average daily flow (ADF)
 - 2) Peak hourly flow (PHF)
- b. Calculate the following and provide calculations in the design submittal:
 - 1) Total static head from the proposed pump inlet to point of discharge. The point of discharge will be to the next lift station wet well on the sewer pressure main.
 - 2) Total dynamic head This must include total static head plus line friction losses for pipe, fittings, and connections from the proposed pump to the point of discharge. This also must include friction losses for flow in the main assuming that a portion of the downstream pumps are running. The City Engineer will be able to assist in this determination.
 - 3) Pumping Rate based upon wet well size and a maximum cycle time at peak hourly flow of six times per hour.
 - 4) Wet Well Capacity based upon a minimum storage above high pump off elevation of two hours of peak hourly flow or 45 minutes with SCADA installed. Wet well capacity shall be determined as follows:

$$V_M = (Q_{PHF} \times 120) + V_{HPO}$$

Where V_M is the volume in the wet well below the inlet pipe, Q_{PHF} is the peak hourly flow in gpm and V_{HPO} is the volume in the wet well below the emergency pump on. The wet well design shall also conform to the following:

- a) The minimum diameter for simplex wet wells is 36 inches
 - b) The minimum diameter for duplex wet wells is 48 inches
 - c) The minimum depth from bottom invert of the inlet to bottom of the wet well is 48 inches.
 - d) The maximum total depth of the wet well from lid to bottom is 12 feet.
 - 5) Select the pump model and horsepower from the ABS pump curves.
 - 6) Select the pressure line type and size as discussed under “pressure sewers” herein.
- c. Additional Limitations or Specifications for Grinder Pumps
- 1) No more than two residences may be served by a simplex grinder station.
 - 2) No more than fifteen single-family residences, or their equivalent, may be served by a single duplex grinder station. This is subject to the review of the City Engineer.
 - 3) All commercial facilities shall have a duplex grinder pump station. In instances where a commercial facility has an average daily flow of less than 16 gpm, and no further development or additional capacity is

Design Guidelines
City Of Osage Beach
SECTION 3 - SEWERAGE DESIGN

- contemplated, a simplex pump and controls maybe installed in a duplex basin.
- 4) Triplex package units or custom-built lift stations are subject to the review and approval of the City Engineer.
 - 5) Each Grinder Pump Station shall include an ABS pump(s) fiberglass basin including internal piping, pump base and guide rail; and ABS Pump Control Panel as described in the ABS specifications
 - a) The basin will be an ABS basin, or the equivalent thereof, and either simplex or duplex as required. All internal piping and pump guide rails shall be stainless steel. A concrete anti-floatation ring shall be cast around the basin base. The basin cover (lid) shall be of steel with minimum thickness of ¼ inch and shall be coated with a high temperature baked epoxy or air-dried epoxy paint, green in color. The lid shall be fully bolted and/or hinged secured.
 - b) All grinder stations of 6.2 HP or less shall have internal discharge piping of 1-1/4 inch stainless steel pipe.
 - c) All grinder stations of more than 6.2 HP shall have stainless steel discharge piping of minimum two inch, or as approved by the City Engineer.
 - d) All grinder stations shall have a brass-bodied globe valve installed in each discharge line within the grinder station at a location approved by the City Engineer.
 - e) The minimum distance from top of grinder basin cover to top of inlet pipe shall be 18 inches.
 - f) The minimum distance from top of grinder basin to bottom of discharge pipe(s) shall be 48 inches.
 - g) The maximum depth of the grinder station basin shall be 12 feet.
 - 6) Electrical Service for Sewage Lift Stations and Grinder Stations
 - a) AmerenUE is the provider for electrical service. The owner, developer, or contractor shall make arrangements with AmerenUE for electrical service to the grinder station. Electrical energy shall be provided on a direct individually metered service of the appropriate capacity for the facility to be served.
 - b) The use of "Add-a-Phase" or other artificial phasing devices is prohibited. When three phase service is required the owner or developer shall make all necessary arrangements with AmerenUE to provide the required service.
 - 7) Grinder Station Electrical Panel: ABS / Electric Control Company shall provide the standard panel developed for the City of Osage Beach of the correct model to match the pump(s). The control panel shall be fully and completely compatible and parts interchangeable with existing city owned units or as directed by the City Engineer. It shall be mounted on galvanized steel rack at a height of approximately 5 feet above finished grade. Each control panel shall have a wiring diagram, or schematic,

Design Guidelines
City Of Osage Beach
SECTION 3 - SEWERAGE DESIGN

attached to the inside of the outer door of the control panel box. All exterior wiring shall be run in rigid metal conduit. All work should be done in accordance with the National Electric Code and all material should be UL approved. The control rack shall be 24-inch frame width. Frame shall be 2 inch square steel tubing (#9 gauge minimum). All components shall be hot dip galvanized. Field cuts must be saw cut. Saw cuts shall be painted with Rust-Oleum or Galva-Well. Below grade metal components shall be painted with a minimum of two coats of Koppers Super Service (blk) Tenemec #450 Heavy Tenemecol coating/sealer, or approved equal. Legs shall be set in concrete. Concrete shall be a minimum of 18 inches deep and 12 inches in diameter. Electrical service wires, pump service wires, and float control wires, shall be run in minimum 2-inch galvanized rigid steel conduit. All bends and fittings shall be long radius bends. An explosion proof wye fitting shall be installed six inches below the control panel. No splice boxes will be permitted within the grinder pump basin. Riser for ground wire shall be in ½ inch rigid, galvanized steel, conduit with grounded bushings, with stubbed and bonding jumper.

- 8) Grounding Rod shall be copper clad grounding rod, ½ inch by 8 feet in length. The rod shall be driven vertically into the ground or as directed by the City Engineer.
- 9) Electric meter, meter base, disconnect, and panel shall comply with AmerenUE Service Manual, Section 5.3.1 (bypass requirements).
- 10) SCADA shall be provided by Systems Manufacturing, 14042 W 107th St. Lenexa, KS, 66215; phone (913) 485-3307.

REQUIRED INSPECTIONS, TESTING, AND STARTUP PROCEDURE

1. Construction Drawings are required for all gravity and pressure sewers and all grinder or sewage lift stations. Such drawings shall be designed and sealed by a Registered Professional Engineer in the State of Missouri.
2. All materials and equipment shall conform to the City of Osage Beach Design Guidelines.
3. All gravity and pressure sewers shall be inspected by Public Works Department Personnel prior to backfill.
4. All gravity and pressure sewers, manholes, and wetwells shall be tested for leakage as specified herein. All tests shall be performed in the presence of City personnel.
5. Grinder and sewage lift stations shall be fully tested for performance and operation in the presence of Public Works Department personnel. Such testing shall include pumping rates, pumping cycle tests including emergency alarm and startup of standby equipment (if so equipped), electrical current and voltage checks. The contractor / developer shall provide the services of a manufactures factory representatives to be present during the tests.
6. Upon completion of all testing startup procedures the Engineering Department will issue a certificate of acceptance. The system will not be connected to the city service or

Design Guidelines
City Of Osage Beach
SECTION 3 - SEWERAGE DESIGN

accepted by the city until the acceptance certificate is issued. If the system can not be accepted no building occupancy permit will be issued.

AS CONSTRUCTED DRAWINGS AND MAINTENANCE DOCUMENTS

The Developer/Contractor shall provide the City Engineering Department with not less than two full sized "As Constructed" drawings certified as being correct record drawings by a Registered Professional Engineer in the State of Missouri.

The developer/contractor shall provide one copy of a certified and recorded utility easement for all sewerlines and grinder station sites to be turned over to the city. Easements shall be prepared and sealed by a Registered Land Surveyor in the State of Missouri.

TYPICAL DETAILS FOR SEWER APPURTENANCES

Sewer appurtenances shall conform to the Typical Details attached hereto.

PUBLIC INFORMATION PACKET – SEWER DESIGN

Applicants for a building or zoning permits will be provided with a “Sewer Information Packet” which reflects the requirements contained in this design manual and pertinent city ordinances. Such packet shall be considered as an approved part of the City Of Osage Beach Design Guideline.

SEPTIC TANK SYSTEMS

City Code Section 710.090 requires that any facility constructed within 300 feet of an existing city sewer must connect to such sewer. There are a few locations within the city where city sewer is not available. In those cases the owner may be authorized by the City Engineer to construct or repair a septic system.

REQUIREMENTS FOR AUTHORIZED PRIVATE SEWAGE DISPOSAL SYSTEMS

A Septic Tank Permit from the City Engineer is required prior to construction. Approved soil morphology, permeability tests and soil percolation tests, site topography, septic tank and absorption system, design by a registered professional engineer are required for the permit.

1. The system must be designed by a Registered Professional Engineer in accordance with Missouri Department of Health Regulations 710.025 through 710.059, Missouri Laws for On-site Sewage Disposal Systems, and 19 CSR 20-3.060 Minimum Standards for On-site Sewage Disposal Systems
2. Soil morphology, permeability tests and soil percolation tests shall be made by a registered professional engineer or state certified soil scientist. Tests and reports shall be in accordance with 19 CSR 20-3, Para (2) Site Evaluation.

Design Guidelines
City Of Osage Beach
SECTION 3 - SEWERAGE DESIGN

3. The Minimum Setback Distances shown in 19 CSR 20-3, Table 1 Minimum Setback Distances shall be strictly followed.
4. Flow Rates or Volumes shall be computed on the basis of 120 gal/day/bedroom or 60 gal/day/person, the minimum flow from a residence shall be 240 gal.
5. The minimum septic tank capacity shall be 1250 gallons. Septic tanks shall be constructed in strict conformance to 19 CSR 20-3, Para. (4).
6. Absorption Systems shall be in accordance with 19 CSR 20-3, Para. (5) Absorption Systems.
7. Alternative Systems shall be in accordance with 19 CSR 20-3, Para (6) Alternative Systems.

A Septic Tank Permit from the Public Works Director is required prior to construction. Approved soil morphology, permeability tests and soil percolation tests, site topography, septic tank and absorption system, design by a registered professional engineer are required for the permit.

END

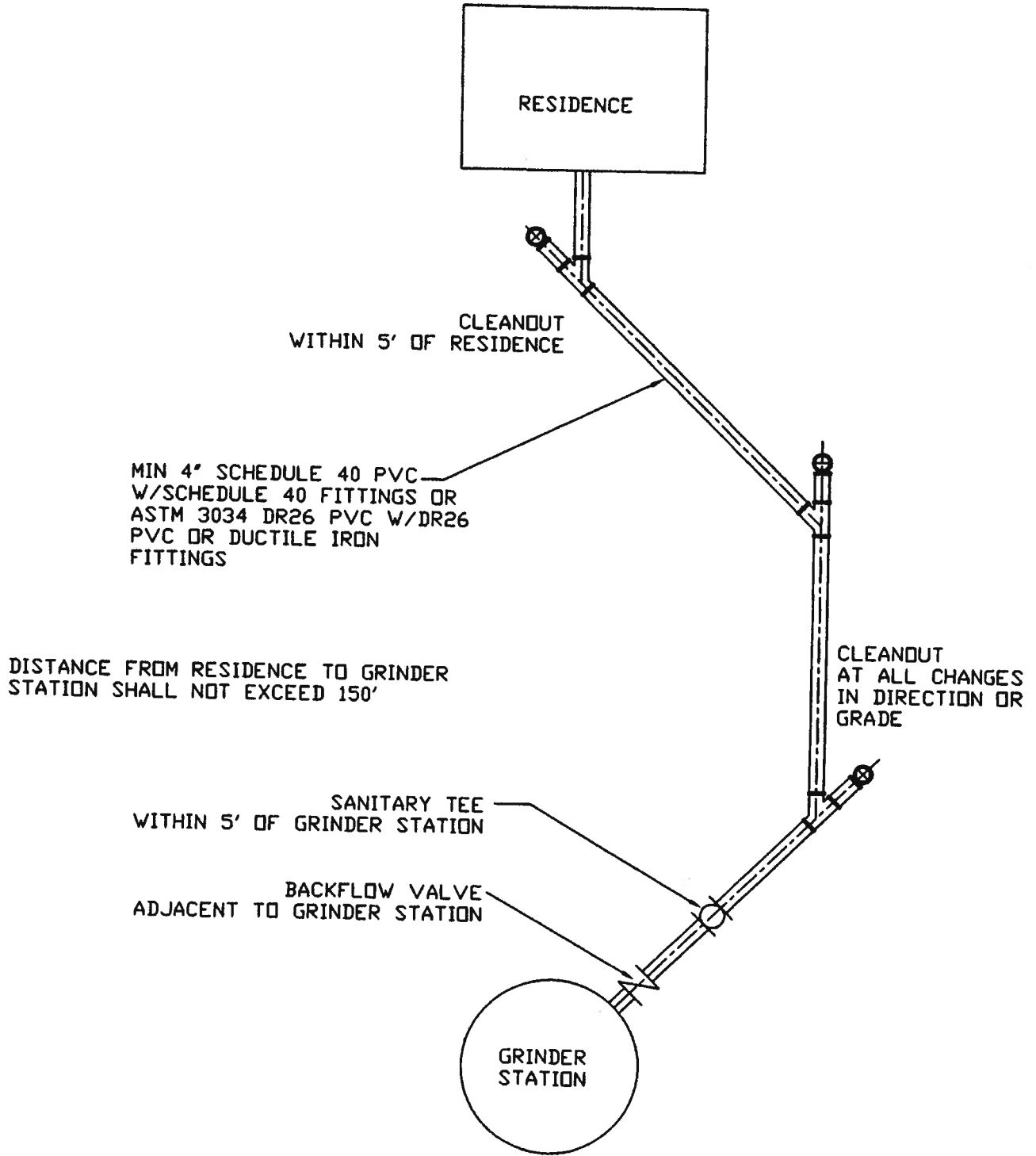

TYPICAL RESIDENTIAL SERVICE CONNECTION
TO GRINDER STATION
 NOT TO SCALE

Revised:	Oct., 2004
By:	sh
Checked By:	JB

CITY OF OSAGE BEACH
 TYPICAL DETAIL
 RESIDENTIAL SERVICE CONNECTION

Design Guideline:	SECTION 3
	SEWERAGE DESIGN
Drawing No.:	III-1

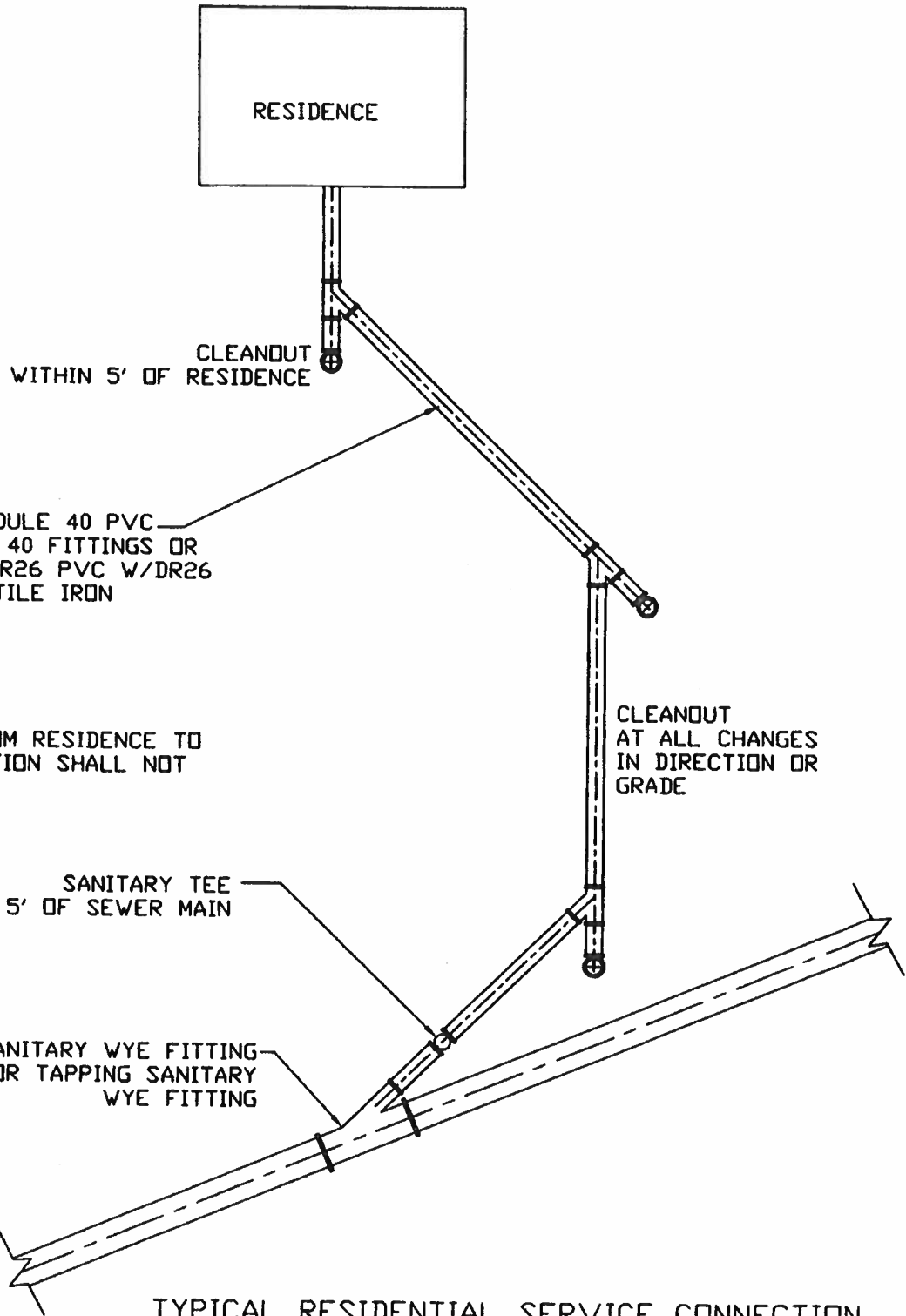

MIN 4' SCHEDULE 40 PVC
 W/SCHEDULE 40 FITTINGS OR
 ASTM 3034 DR26 PVC W/DR26
 PVC OR DUCTILE IRON
 FITTINGS

DISTANCE FROM RESIDENCE TO
 GRINDER STATION SHALL NOT
 EXCEED 150'

SANITARY TEE
 WITHIN 5' OF SEWER MAIN

SANITARY WYE FITTING
 OR TAPPING SANITARY
 WYE FITTING

TYPICAL RESIDENTIAL SERVICE CONNECTION
 TO GRAVITY SEWER MAIN
 NOT TO SCALE

Revised: OCT., 2004
Checked By: JB

CITY OF OSAGE BEACH
 TYPICAL DETAIL
 RESIDENTIAL SERVICE CONNECTION

Design Guideline: SECTION 3
SEWERAGE DESIGN
Drawing No.: III-2

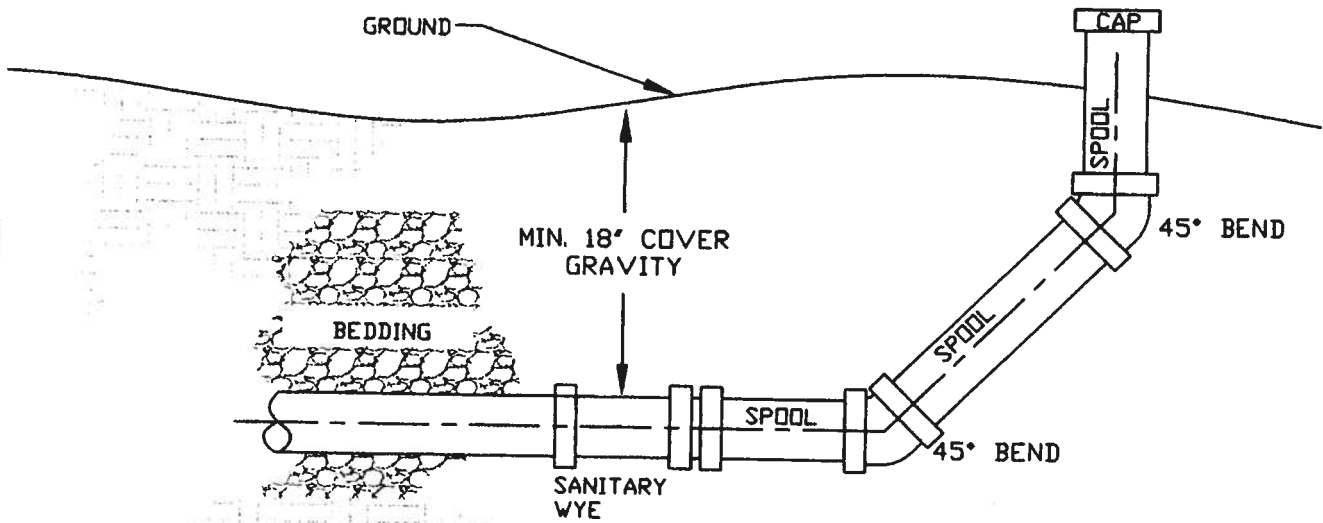

Revised:
Oct., 2004
sh
Checked By:
JB

CITY OF OSAGE BEACH
 TYPICAL DETAIL
 SANITARY SEWER CLEANOUT DETAIL
 NOT TO SCALE

Design Guideline:
SECTION 3
SEWERAGE DESIGN
Drawing No.:
III-3

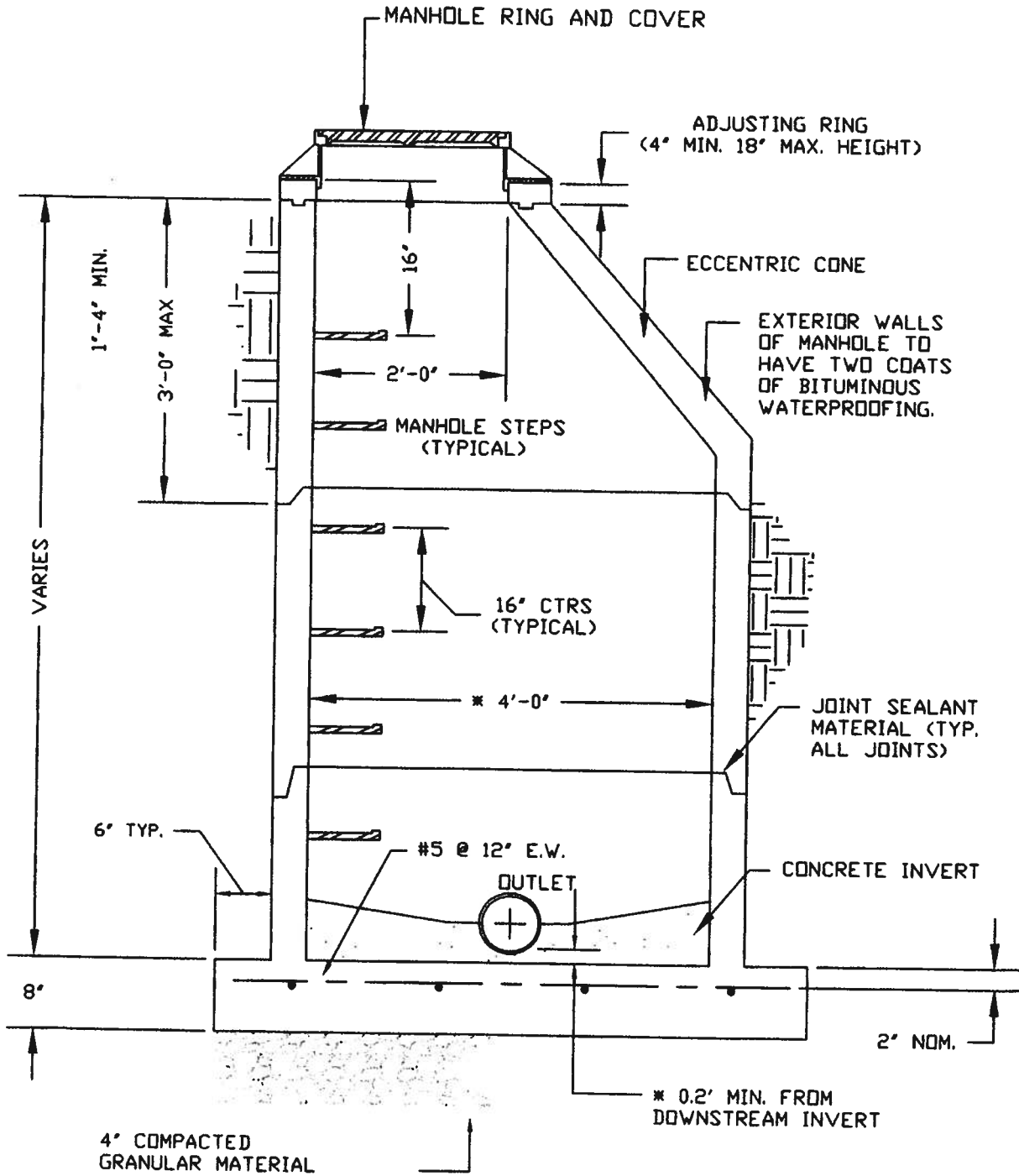

* UNLESS OTHERWISE NOTED ON PLANS - TYPICAL.

Revised:	Apr., 2003
Checked By:	JB

CITY OF OSAGE BEACH
TYPICAL DETAIL
STANDARD PRECAST MANHOLE
NOT TO SCALE

Design Guideline:	SECTION 3
	SEWERAGE DESIGN
Drawing No.:	III-4

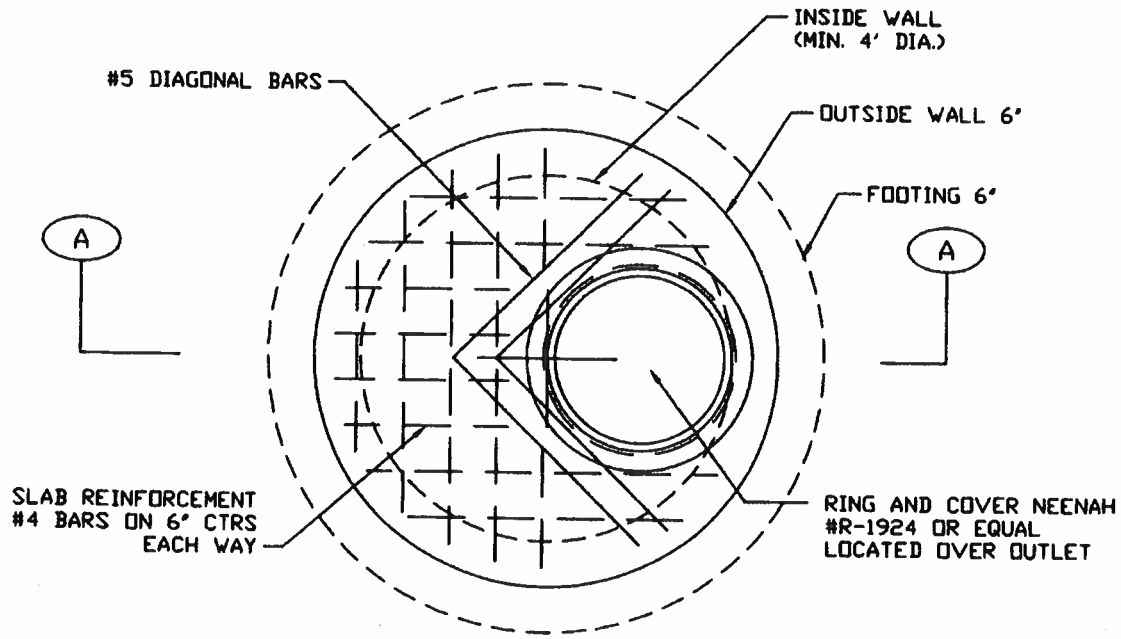

TOP PLAN

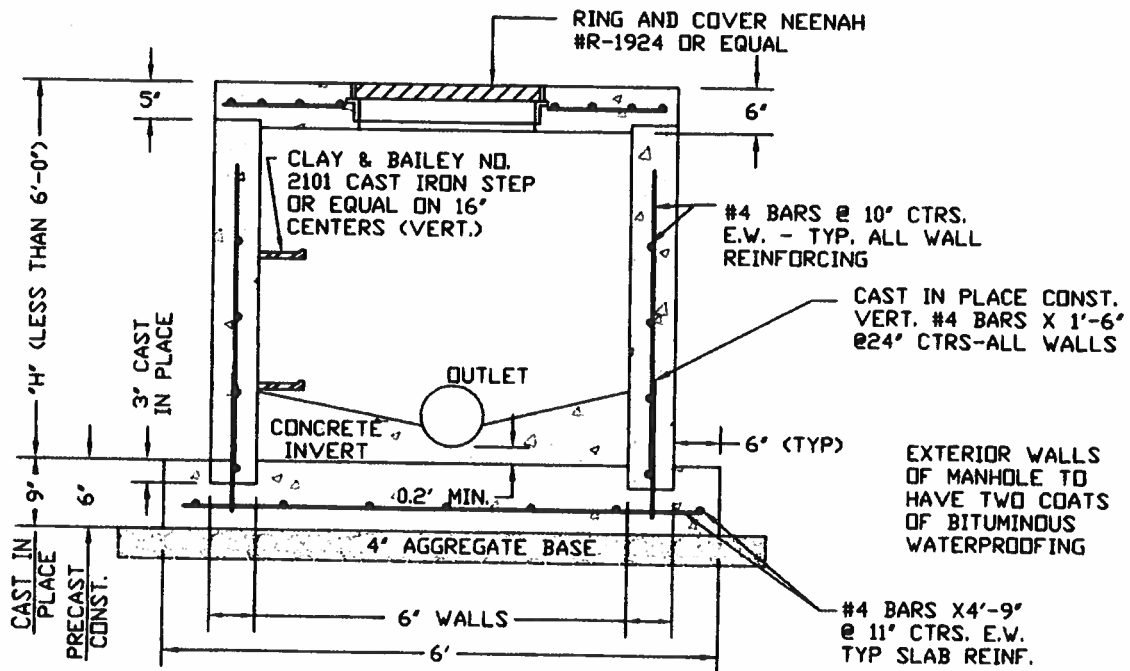

SECTION A-A

Revised:	Oct., 2004
Checked By:	JB

CITY OF OSAGE BEACH
 TYPICAL DETAIL
 FLAT TOP MANHOLE
 NOT TO SCALE

Design Guideline:	SECTION 3
	SEWERAGE DESIGN
Drawing No.:	III-5

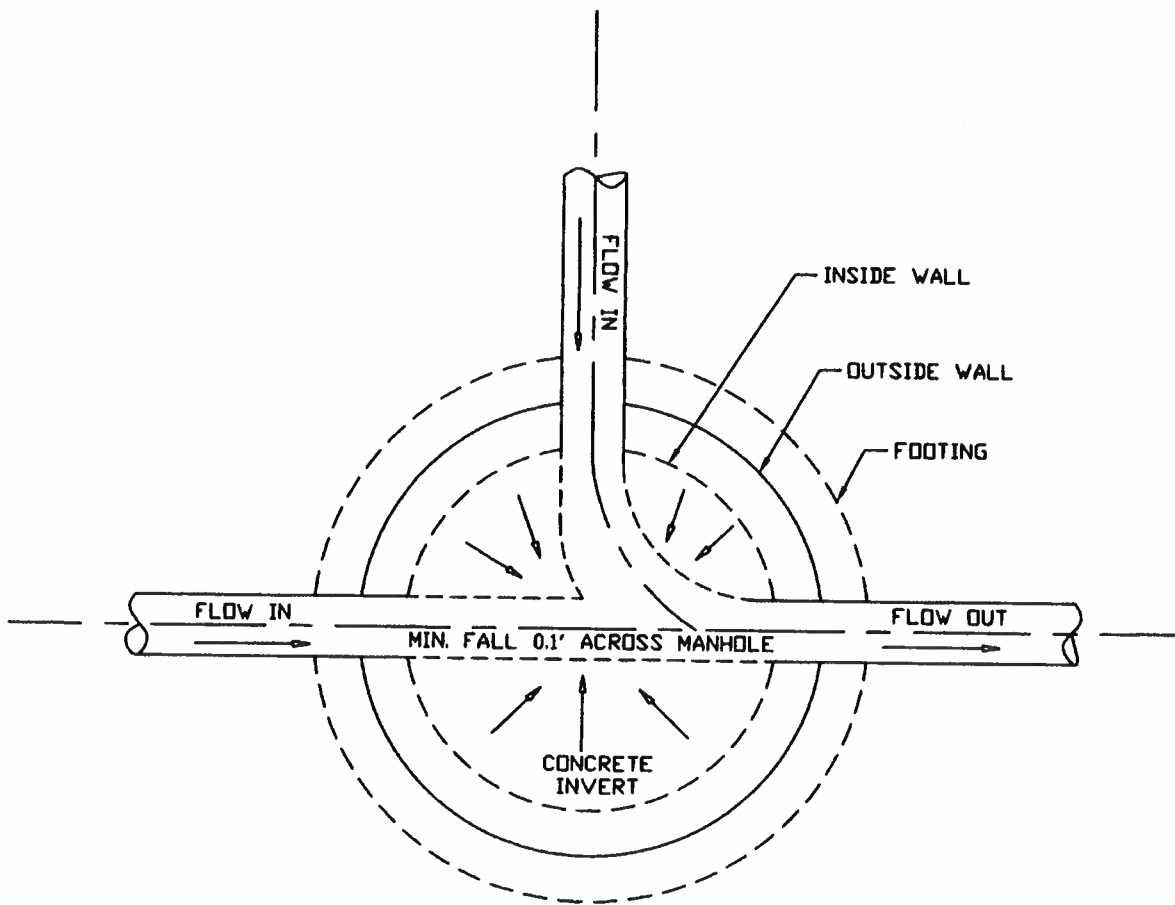

Revised:	Oct., 2004
By:	sh
Checked By:	JB

CITY OF OSAGE BEACH
 TYPICAL DETAIL
 MANHOLE INVERT DETAIL

NOT TO SCALE

Design Guideline:	SECTION 3
	SEWERAGE DESIGN
Drawing No.:	III-6

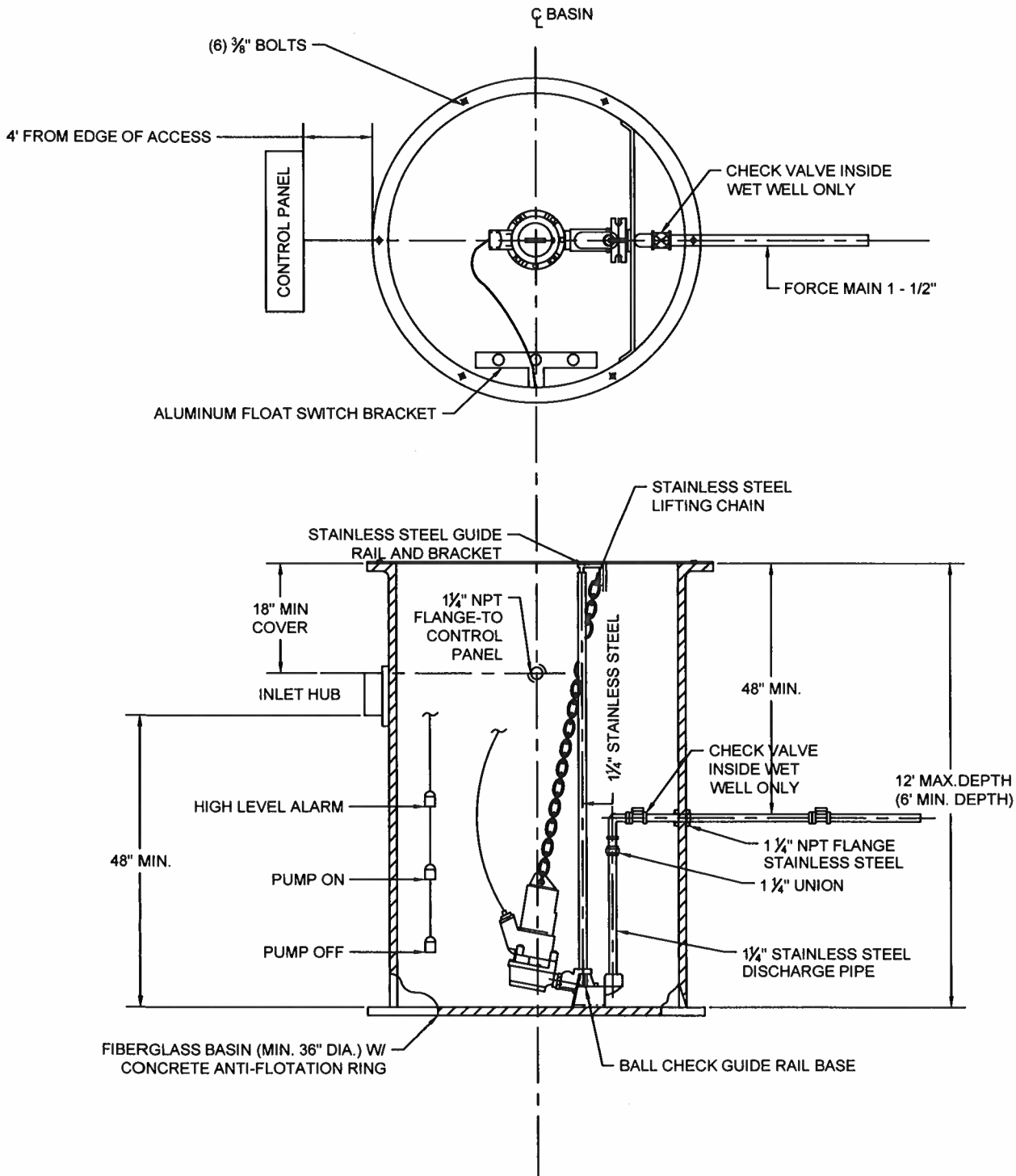

Date Revised:	JUNE, 2017
By:	MLM
Checked By:	NLE

CITY OF OSAGE BEACH
TYPICAL DETAIL
SIMPLEX PUMP STATION

Design Guideline:	SECTION 3
	SEWERAGE DESIGN
Drawing No.:	III-7

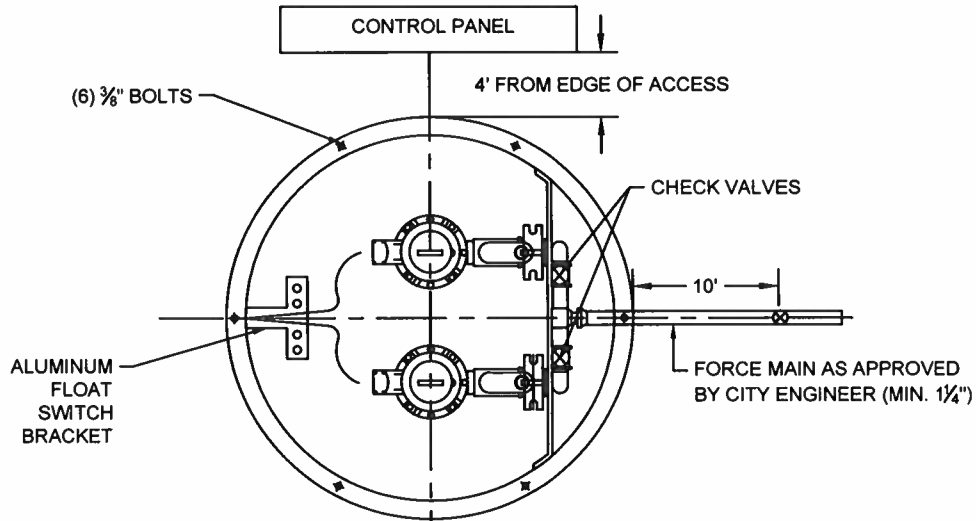

THIS IS A TYPICAL INSTALLATION DRAWING.
NOT TO BE USED FOR CONSTRUCTION.

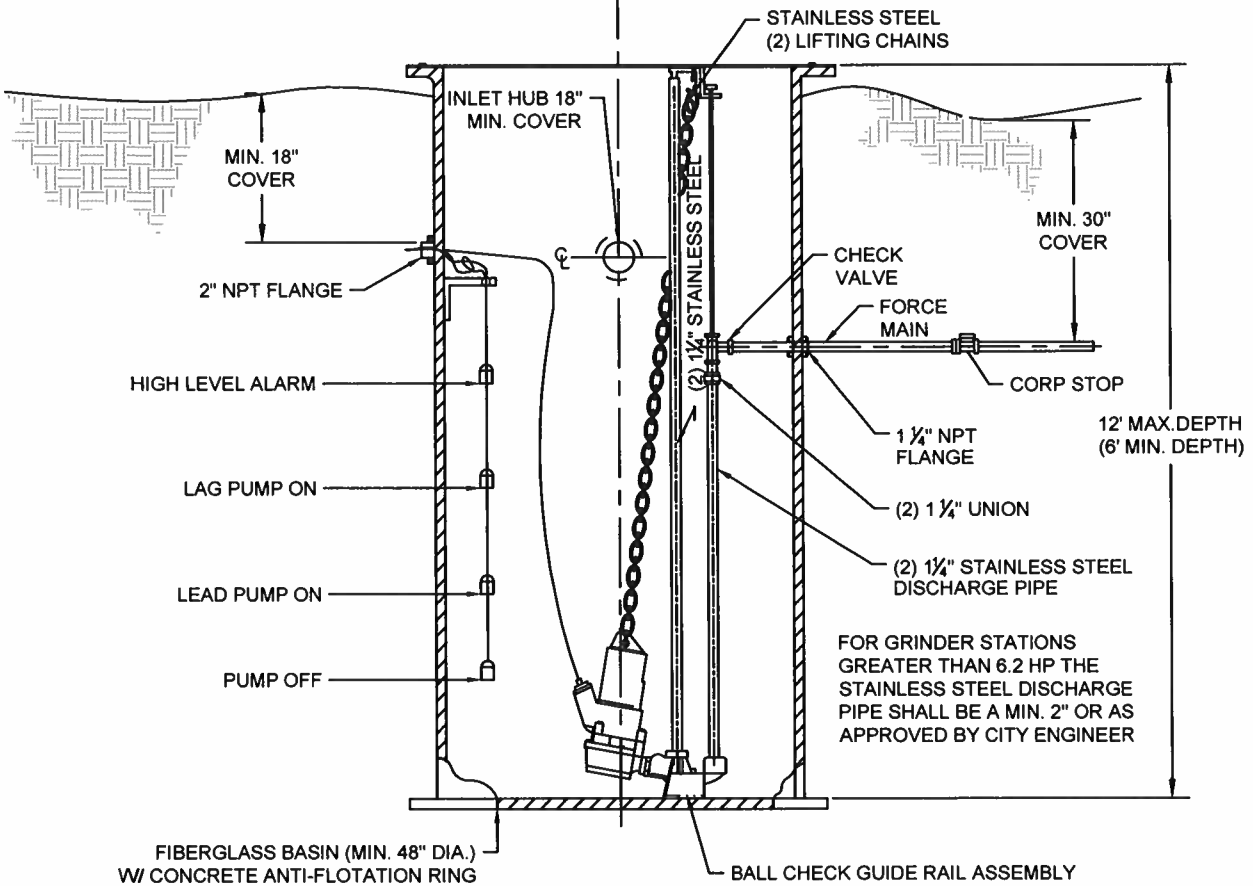

Date Revised:	JUNE, 2017
Checked By:	NLE

**CITY OF OSAGE BEACH
TYPICAL DETAIL
DUPLEX PUMP STATION**

Design Guideline:	SECTION 3
	SEWERAGE DESIGN
Drawing No.:	III-8

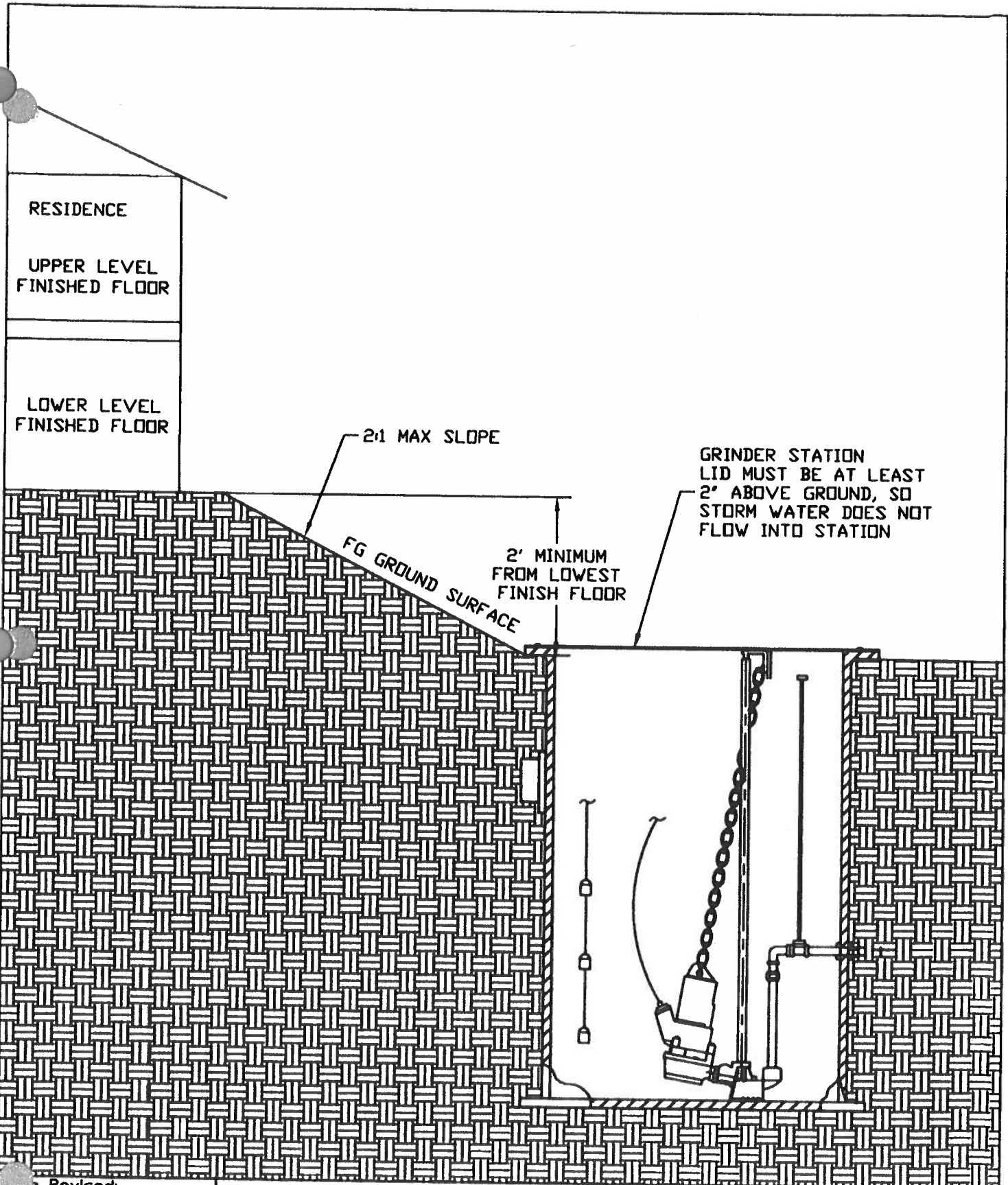

Revised:
 NOV., 2009
 By:
 cps
 Checked By:

CITY OF OSAGE BEACH
 TYPICAL DETAIL
 WET WELL ELEVATION

Design Guideline:
 SECTION 3
 SEWERAGE DESIGN
 Drawing No.:
 III-9

FRAME SHALL BE 2" SQUARE STEEL TUBING (#9 GAUGE MINIMUM). HEAVY DUTY GALVANIZED UNI-STRUT MAY BE USED. ALL COMPONENTS SHALL BE HOT DIP GALVANIZED. FIELD CUTS MUST BE SAW CUT. SAW CUTS SHALL BE PAINTED WITH RUST-OLEUM OR GALVA-WELL. BELOW GRADE METAL COMPONENTS SHALL BE PAINTED WITH A MINIMUM OF TWO COATS OF KOPPERS SUPER SERVICE (blk.) OR TENEMEC #450 HEAVY TENEMECOL COATING/SEALER OR APPROVED EQUAL.

* ALL ELECTRIC WORK SHALL BE DONE IN ACCORDANCE WITH THE NATIONAL ELECTRIC CODE AND ALL MATERIAL SHALL BE UL APPROVED.

THE PUMP CONTROL PANEL SHALL BE PROVIDED BY ABS OR AS SUPPLIED BY MUNICIPAL EQUIPMENT COMPANY, ST. LOUIS, MO., OF THE CORRECT MODEL TO MATCH THE PUMP. IT SHALL BE MOUNTED APPROXIMATELY 5' ABOVE FINISHED GRADE. EACH CONTROL PANEL SHALL HAVE A WIRING DIAGRAM OR SCHEMATIC ATTACHED TO THE INSIDE OF THE OUTER DOOR OR THE CONTROL PANEL BOX.

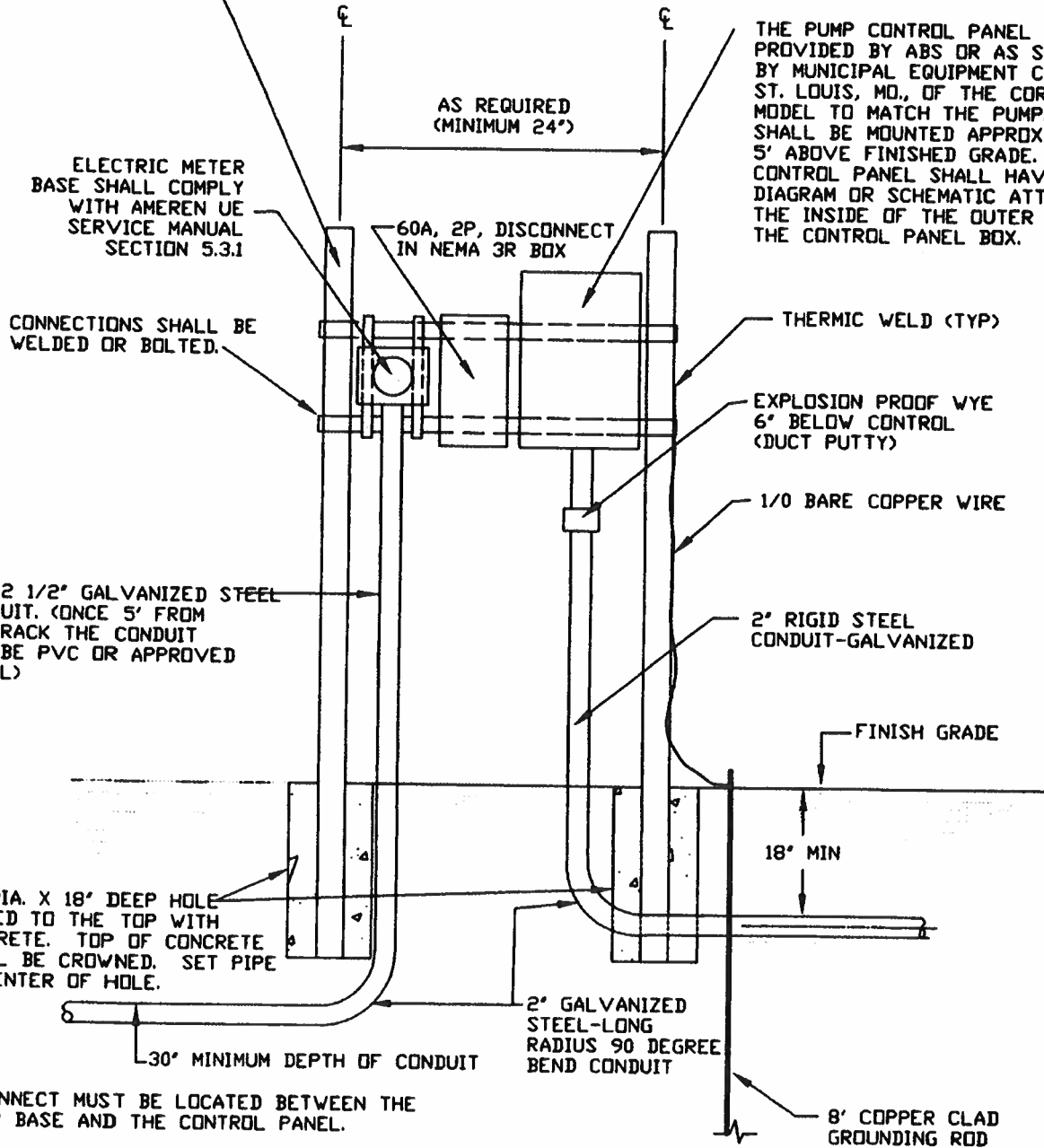

Date Revised:
OCTOBER 2004
 y: sh
 Checked By: JB

CITY OF OSAGE BEACH
TYPICAL DETAIL
GRINDER STATION RACK
 NOT TO SCALE

Design Guideline:
SECTION 3
SEWERAGE DESIGN
 Drawing No:
III-9A